

# S8BX

LRP 1/8 SCALE HIGH-PERFORMANCE  
4WD NITRO COMPETITION BUGGY

## Front Suspension

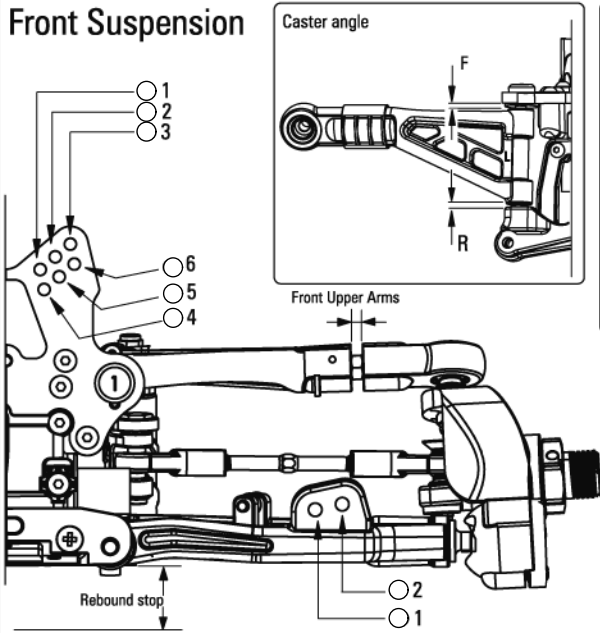

Caster angle

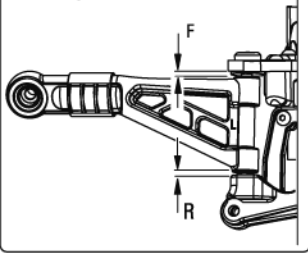

Front Upper Arms

Front Roll Center

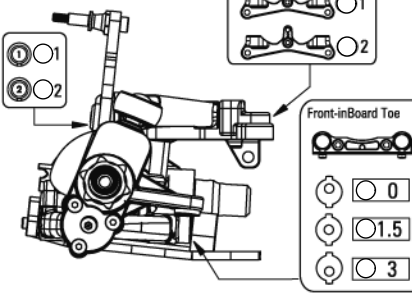

Caster angle F \_\_\_\_\_ mm  
R \_\_\_\_\_ mm

Camber front \_\_\_\_\_ mm  
Rebound stop \_\_\_\_\_ mm

Notes : \_\_\_\_\_

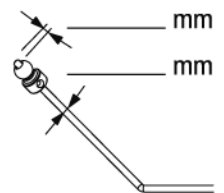
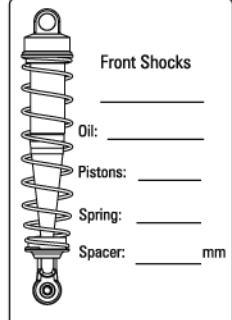

## Rear Suspension

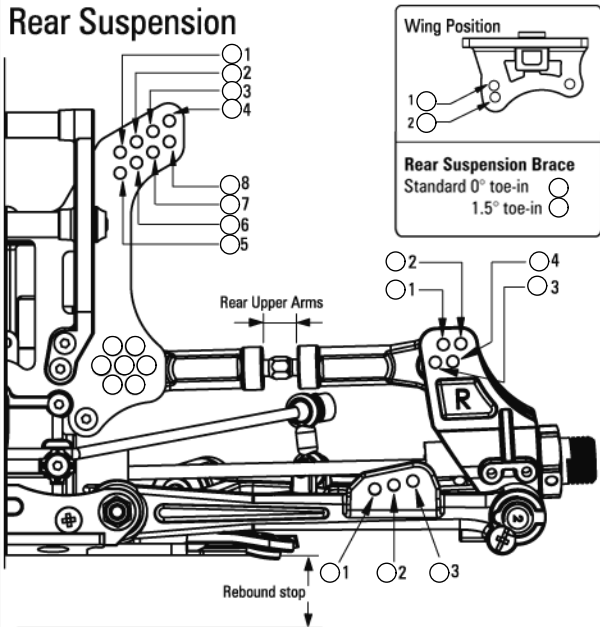

Wing Position

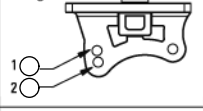

Rear Suspension Brace  
Standard 0° toe-in  
1.5° toe-in

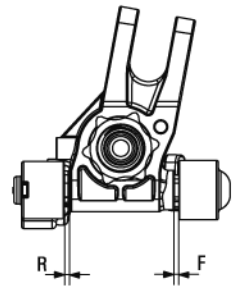
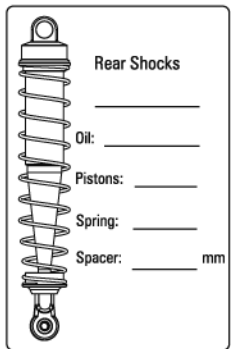
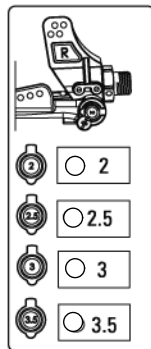

Wheelbase adjustment  
F \_\_\_\_\_ mm  
R \_\_\_\_\_ mm

Camber rear \_\_\_\_\_ mm  
Rebound stop \_\_\_\_\_ mm

Notes : \_\_\_\_\_

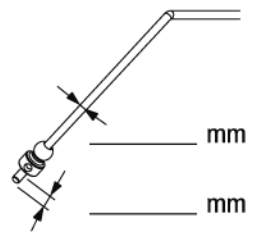

## Tire

Front Type : \_\_\_\_\_ Foam : \_\_\_\_\_  
Rear Type : \_\_\_\_\_ Foam : \_\_\_\_\_

## Clutch

Clutch shoes : \_\_\_\_\_  
Spring : \_\_\_\_\_ mm  
Clutch bell /Spur gear : \_\_\_\_\_

## Diff Oil

Front : # \_\_\_\_\_  
Center : # \_\_\_\_\_  
Rear : # \_\_\_\_\_

## Engine

Type : \_\_\_\_\_  
Gasket : \_\_\_\_\_ mm Muffler : \_\_\_\_\_  
Plug : \_\_\_\_\_ Fuel : \_\_\_\_\_

## Track Conditions

Size :  Open  Med  Tight  
Traction :  High  Med  Low  
Surface :  Smooth  Med  Bumpy

Name : \_\_\_\_\_  
Date : \_\_\_\_\_  
Track : \_\_\_\_\_