

S8 BXR EVO

1/8 HIGH-PERFORMANCE
NITRO 4WD R/C COMPETITION BUGGY

Front Suspension

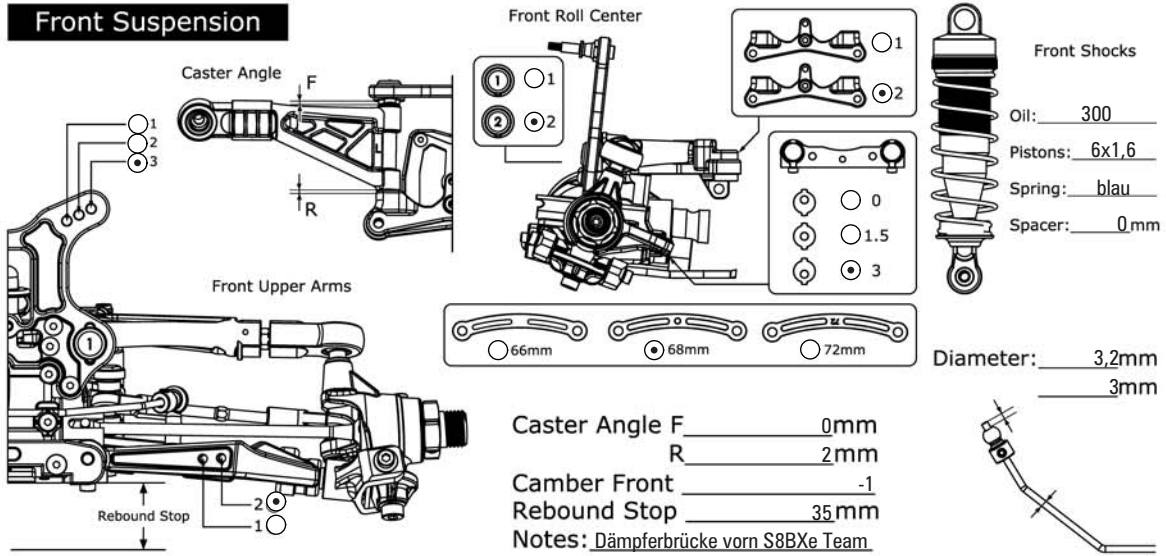

Front Roll Center

Caster Angle F _____ R _____

Front Upper Arms

Rebound Stop

Front Shocks

Oil: 300
Pistons: 6x1,6
Spring: blau
Spacer: 0mm

Diameter: 3,2mm
3mm

Notes: Dämpferbrücke vorn S8BxE Team

Rear Suspension

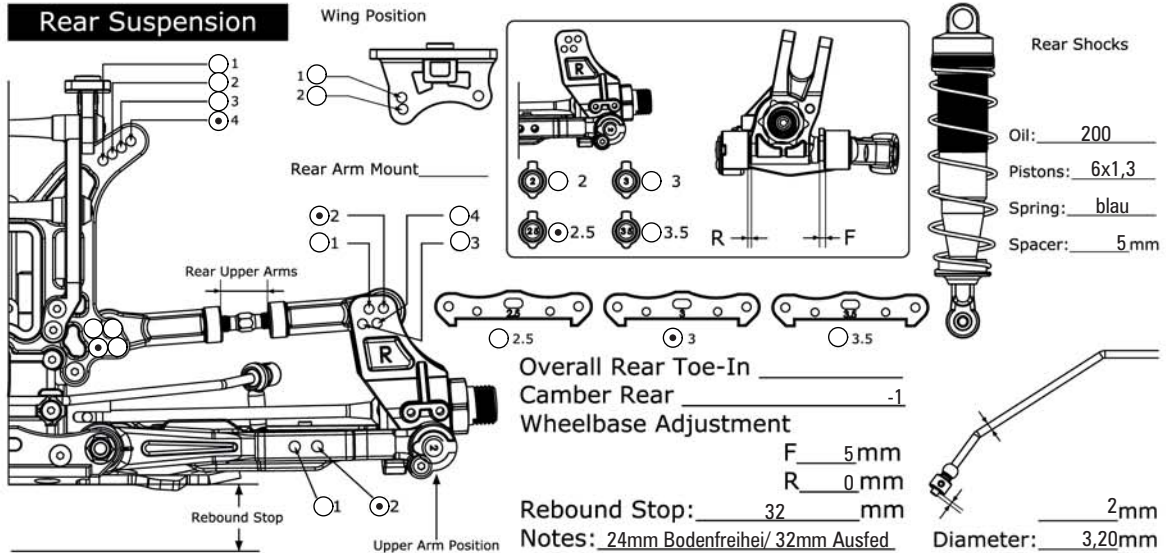

Wing Position

Rear Arm Mount

Rear Upper Arms

Rebound Stop

Upper Arm Position

Rear Shocks

Oil: 200
Pistons: 6x1,3
Spring: blau
Spacer: 5mm

Notes: 24mm Bodenfreiheit/ 32mm Ausfed.

Tire

Front Schumacher
Type: Mini Pin
Foam: AKA

Rear Schumacher
Type: Mini Pin
Foam: AKA

Clutch

Clutch Shoes: 3xAlu
Spring: 1,1 mm
Clutch Bell / Spur Gear: 13/46

Diff Oil

Front: # 60000
Center: # 40000
Rear: # 20000

Engine

Type: LRP ZR21x Spec2
Gasket: 7mm/Tankzeit 8,0min mm Muffler: LRP Enduro 46 EFRA 2076
Plug: Orion 5 Fuel: LRP 25%

Track Conditions

Size: Open Med Tight
Traction: High Med Low
Surface: Smooth Med Bumpy

Name: Philipp Guschl
Date: 23.01.2011
Track: Quakenbrück Indoor