

S8 BXR EVO

1/8 HIGH-PERFORMANCE
NITRO 4WD R/C COMPETITION BUGGY

Front Suspension

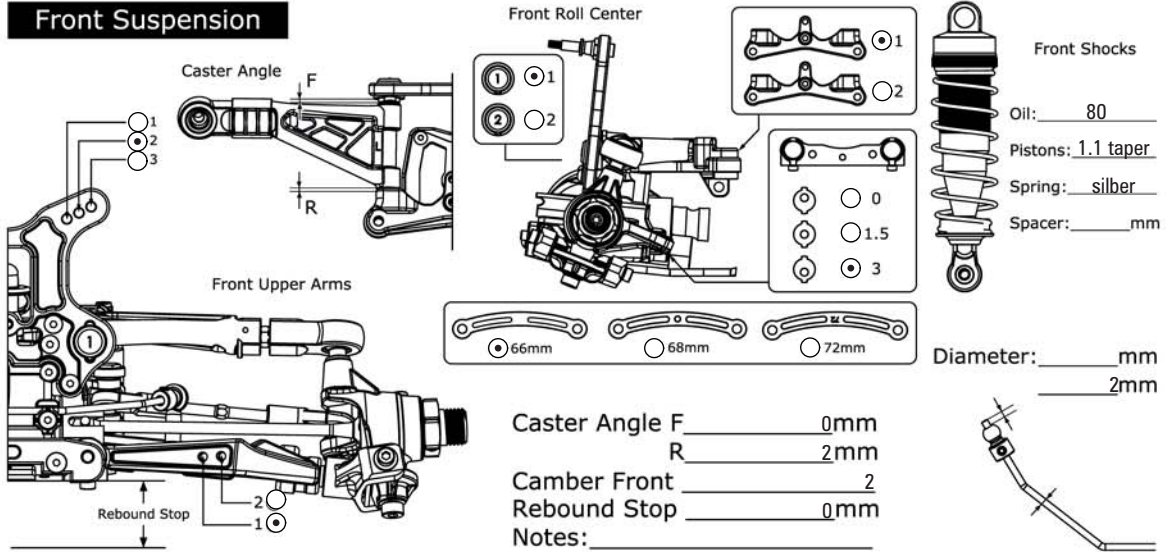

Front Roll Center

Caster Angle F _____ R _____

Front Upper Arms

Rebound Stop

Front Shocks

Oil: 80

Pistons: 1.1 taper

Spring: silber

Spacer: _____ mm

Diameter: _____ mm

_____ 2mm

Front Roll Center Options:

- 1
- 2
- 0
- 1.5
- 3

Front Upper Arms Options:

- 66mm
- 68mm
- 72mm

Adjustment Values:

Caster Angle F _____ 0mm

R _____ 2mm

Camber Front _____ 2

Rebound Stop _____ 0mm

Notes: _____

Rear Suspension

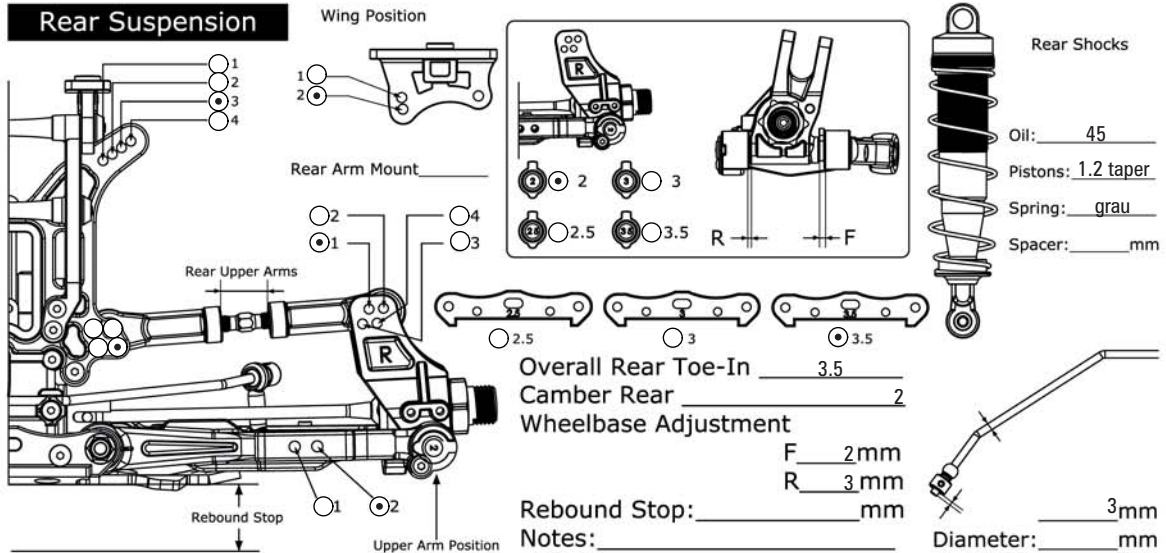

Wing Position

Rear Arm Mount

Rear Upper Arms

Rebound Stop

Upper Arm Position

Rear Shocks

Oil: 45

Pistons: 1.2 taper

Spring: grau

Spacer: _____ mm

Wing Position Options:

- 1
- 2
- 3
- 4

Rear Arm Mount Options:

- 2
- 1
- 4
- 3

Rear Upper Arms Options:

- 2.5
- 3
- 3.5

Adjustment Values:

Overall Rear Toe-In _____ 3.5

Camber Rear _____ 2

Wheelbase Adjustment

F _____ 2mm

R _____ 3mm

Rebound Stop: _____ mm

Notes: _____

Diameter: _____ mm

_____ 3mm

Tire

Front VTEC

Type: Banzai SS

Foam: LRP High Response

Rear VTEC

Type: Banzai SS

Foam: LRP High Response

Clutch

Clutch Shoes: Aluminium

Spring: 1.0 mm

Clutch Bell / Spur Gear: 13/45

Diff Oil

Front: # 5000

Center: # 5000

Rear: # 1000

Engine

Type: LRP ZR.21X Spec.2

Gasket: 7 mm

Plug: OS P3

Muffler: LRP

Fuel: LRP Power Fuel 25%

Track Conditions

Size: Open Med Tight

Traction: High Med Low

Surface: Smooth Med Bumpy

Name: Jörn Neumann

Date: 8.-14. November 2010

Track: Pattya/Thailand World Championship