

S8 BXR EVO

1/8 HIGH-PERFORMANCE
NITRO 4WD R/C COMPETITION BUGGY

Front Suspension

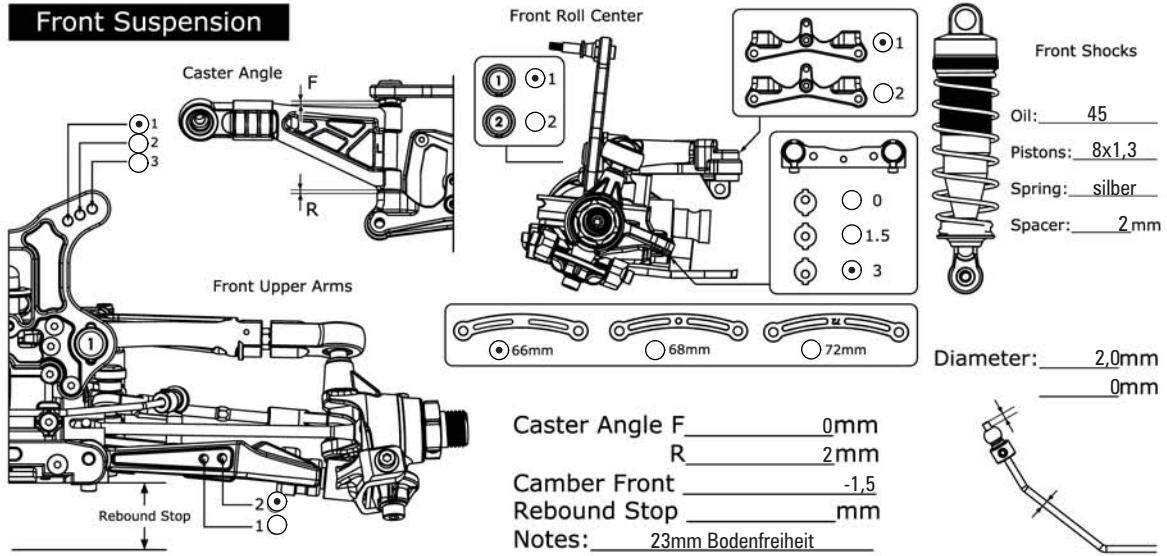

Front Roll Center

Caster Angle F _____ R _____

Front Upper Arms

Rebound Stop

Front Shocks

Oil: 45

Pistons: 8x1,3

Spring: silber

Spacer: 2mm

Diameter: 2,0mm
0mm

Notes: 23mm Bodenfreiheit

Rear Suspension

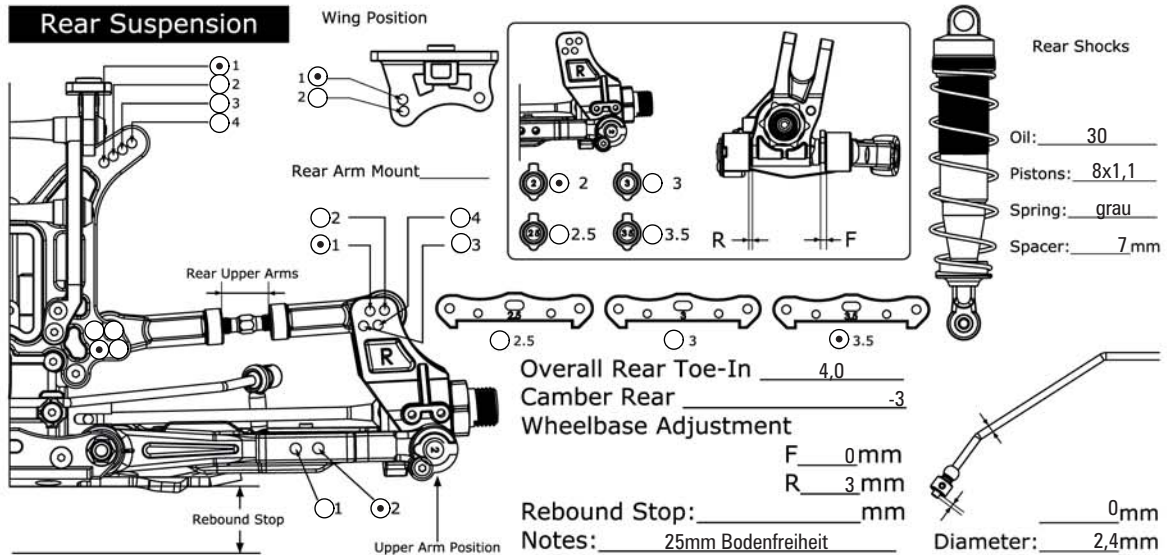

Wing Position

Rear Arm Mount

Rear Upper Arms

Rebound Stop

Upper Arm Position

Rear Shocks

Oil: 30

Pistons: 8x1,1

Spring: grau

Spacer: 7mm

Diameter: 2,4mm

Notes: 25mm Bodenfreiheit

Tire

Front Suicide

Type: SS

Foam: gelb

Rear Suicide

Type: SS

Foam: gelb

Clutch

Clutch Shoes: 3xALU

Spring: 0,9 mm

Clutch Bell / Spur Gear: 14/46

Diff Oil

Front: # 5000

Center: # 5000

Rear: # 3000

Engine

Type: LRP

Gasket: 6,5 mm

Plug: Orion 5

Muffler: LRP

Fuel: 25%

Track Conditions

Size: Open Med Tight

Traction: High Med Low

Surface: Smooth Med Bumpy

Name: Philipp Guschl

Date: 11-13.02.2011

Track: GP Montpellier Frankreich