

### Front Suspension

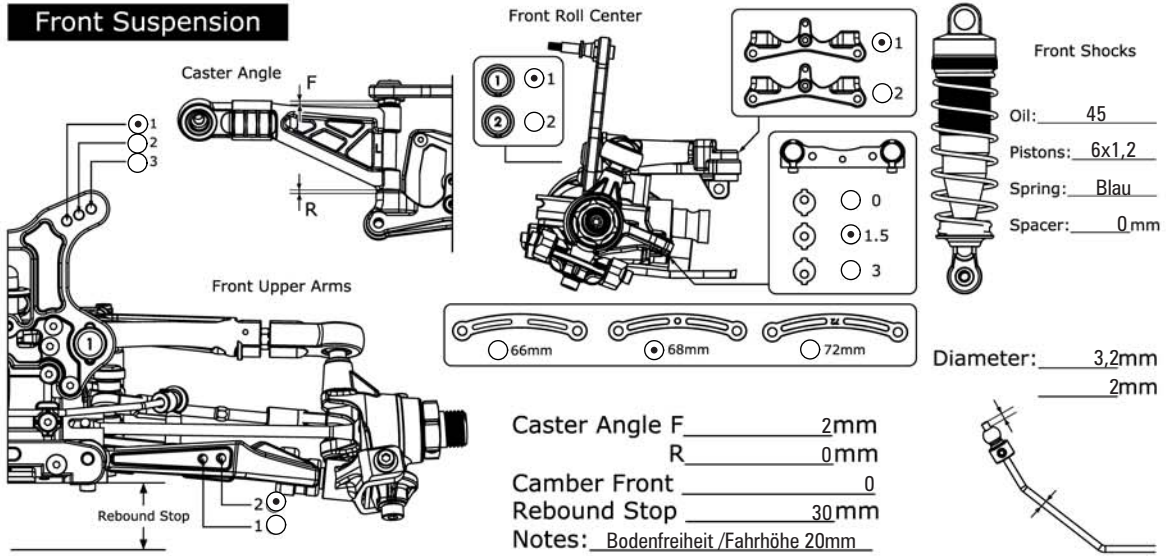

**Front Roll Center**

**Caster Angle** F \_\_\_\_\_ R \_\_\_\_\_

**Front Upper Arms**

**Rebound Stop**

**Front Shocks**

Oil: 45

Pistons: 6x1,2

Spring: Blau

Spacer: 0mm

Diameter: 3,2mm  
2mm

**Wings:** 66mm, 68mm, 72mm

**Roll Center Options:** 1, 2, 0, 1.5, 3

**Adjustments:** Caster Angle F 2mm, R 0mm; Camber Front 0; Rebound Stop 30mm

Notes: Bodenfreiheit /Fahrhöhe 20mm

### Rear Suspension

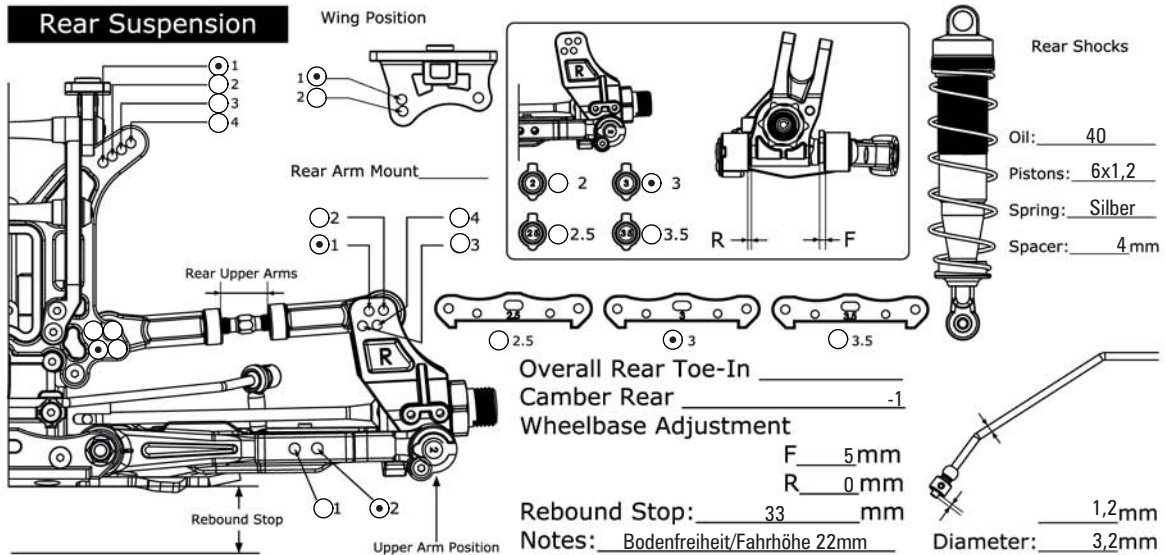

**Wing Position**

**Rear Arm Mount**

**Rear Upper Arms**

**Rebound Stop**

**Upper Arm Position**

**Rear Shocks**

Oil: 40

Pistons: 6x1,2

Spring: Silber

Spacer: 4mm

**Wings:** 2.5, 3, 3.5

**Adjustments:** Overall Rear Toe-In \_\_\_\_\_; Camber Rear -1; Wheelbase Adjustment F 5mm, R 0mm; Rebound Stop: 33mm

Notes: Bodenfreiheit/Fahrhöhe 22mm

Diameter: 3,2mm

### Tire

Front AKA super soft+

Type: LRP Haftmittel

Foam: AKA

Rear AKA super soft+

Type: LRP Haftmittel

Foam: AKA

### Clutch

Clutch Shoes: 3x Alu

Spring: 1,1mm

Clutch Bell / Spur Gear: 13/45

### Diff Oil

Front: # 7000

Center: # 30000

Rear: # 7000

### Engine

Type: LRP ZR.21x SPEC.2

Gasket: 7,0mm

Plug: Orion5

Muffler: LRP Enduro 2076

Fuel: LRP 25%

### Track Conditions

Size:  Open  Med  Tight

Traction:  High  Med  Low

Surface:  Smooth  Med  Bumpy

Name: Philipp Guschl

Date: 01.10.2010

Track: Leipzig Messe Cup