

S8 BXR EVO

1/8 HIGH-PERFORMANCE
NITRO 4WD R/C COMPETITION BUGGY

Front Suspension

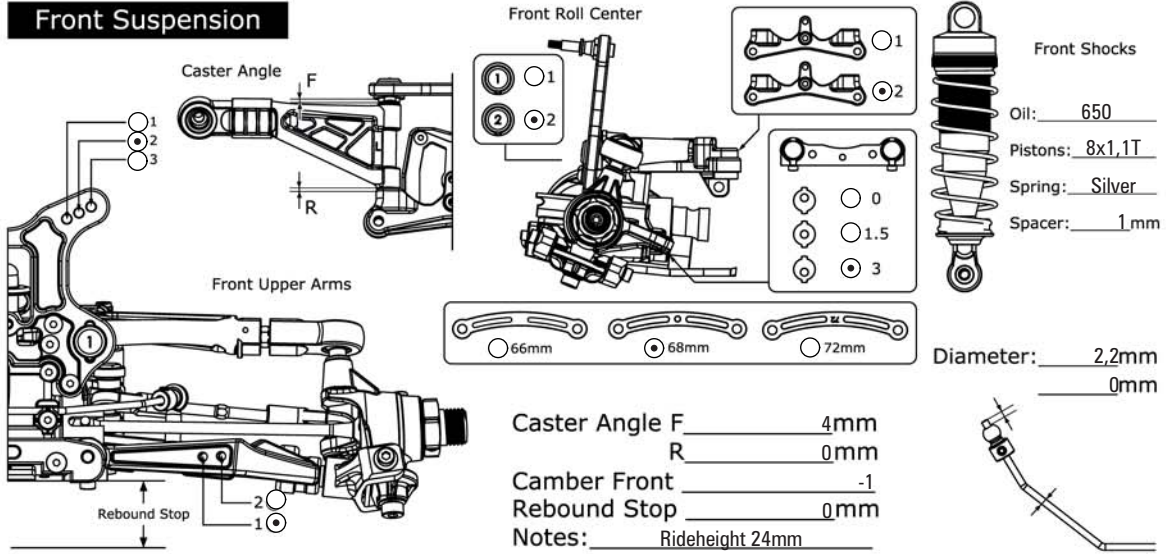

Front Roll Center

Caster Angle F _____ R _____

Front Upper Arms

Rebound Stop

Front Shocks

Oil: 650
Pistons: 8x1,1T
Spring: Silver
Spacer: 1mm

Front Roll Center Options:

- 1
- 2
- 0
- 1.5
- 3

Front Upper Arms Options:

- 66mm
- 68mm
- 72mm

Front Shocks Options:

- Diameter: 2,2mm
- 0mm

Adjustment Values:

Caster Angle F _____ 4mm
R _____ 0mm
Camber Front _____ -1
Rebound Stop _____ 0mm
Notes: Rideheight 24mm

Rear Suspension

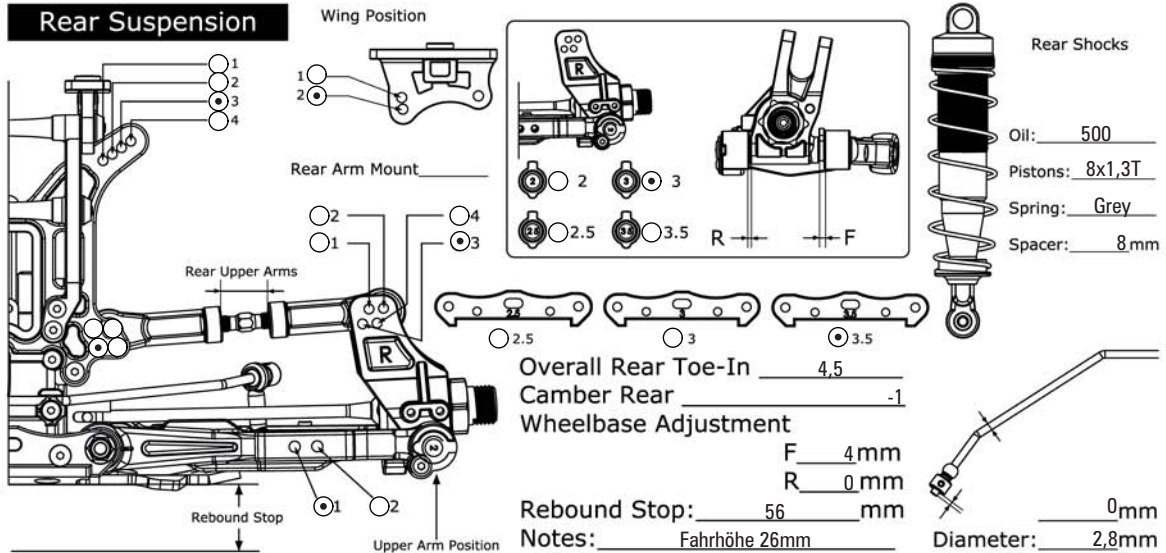

Wing Position

Rear Arm Mount

Rear Upper Arms

Rebound Stop

Upper Arm Position

Rear Shocks

Oil: 500
Pistons: 8x1,3T
Spring: Grey
Spacer: 8mm

Rear Arm Mount Options:

- 1
- 2
- 2.5
- 3
- 3.5

Upper Arm Position Options:

- 2.5
- 3
- 3.5

Adjustment Values:

Overall Rear Toe-In _____ 4,5
Camber Rear _____ -1
Wheelbase Adjustment
F _____ 4mm
R _____ 0mm
Rebound Stop: _____ 56mm
Notes: Fahrhöhe 26mm

Rear Shocks Options:

- Diameter: 2,8mm
- 0mm

Tire

Front: JConcepts
Type: Crossbows blue
Foam: JC blue

Rear: JConcepts
Type: Crossbows blue
Foam: JC blue

Clutch

Clutch Shoes: XTEC Aluminium
Spring: 3x1,0 mm
Clutch Bell / Spur Gear: 14/46

Diff Oil

Front: # 7000
Center: # 7000
Rear: # 3000

Engine

Type: LRP ZZ.21C
Gasket: 6,0 mm
Muffler: LRP Enduro46
Plug: Orion 5
Fuel: LRP 25%

Track Conditions

Size: Open Med Tight
Traction: High Med Low
Surface: Smooth Med Bumpy

Name: Guschl, Philipp
Date: 13.-15.05.2011
Track: Sand am Main / Germany