

S10 TC BLAST 2

SETUP SHEET

FRONT SUSPENSION

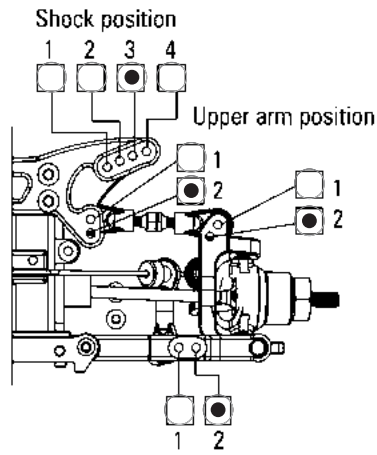

Caster angle
 Standard: 10°
 Option: 4°

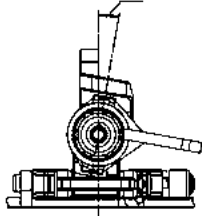

Sway bar
 Diameter: _____ mm

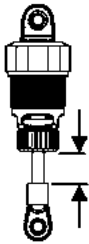
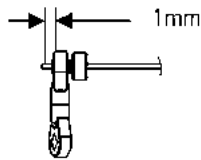

Front shock
 Oil: 40
 Pistons: std
 Spacer: 0
 Springs: weiß

Toe angle

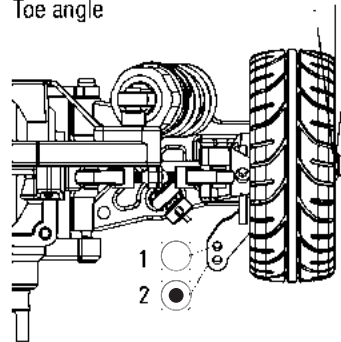

Front toe angle +0,5°
 Notes _____
 Rear toe angle 3°
 Notes _____

Camber angle

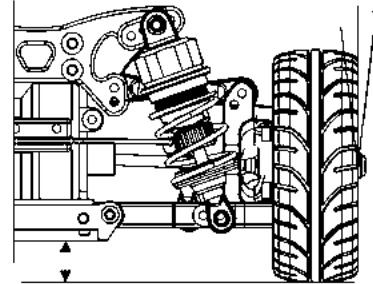

Camber front -1,5°
 Notes _____
 Camber rear -1,5°
 Notes _____

Rideheight front 5,2mm
 Rideheight rear 5,8mm

REAR SUSPENSION

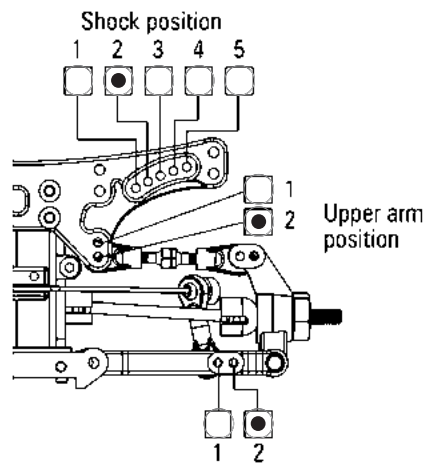

Wheelbase adjustment

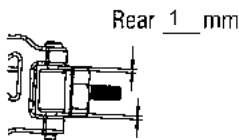

Front 1 mm

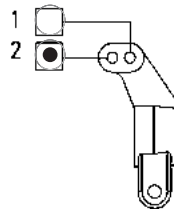

Sway bar
 Diameter: _____ mm

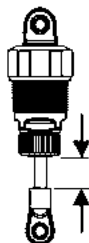
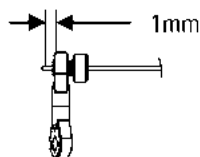

Rear shock
 Oil: 20
 Pistons: std
 Spacer: 0
 Springs: weiß

Tire

Front	Rear
Type: <u>Classic</u>	Type: <u>Classic</u>
Foam: <u>Classic</u>	Foam: <u>Classic</u>

Motor: <u>17,5T</u>	Battery: <u>LRP 4600 (79)</u>
Spur Gear: <u>58</u>	ESC: <u>LRP Flow</u>
Pinion Gear: <u>28</u>	Servo: _____

Track conditions

Size: Open Med Tight
 Traction: High Med Low
 Surface: Carpet Asphalt

Diff Oil

Front: 500000
 Rear: 20

Comment

vorn / hinten keine Stabis Karo Hemi Cuda

Name: Thomas Nitschke
 Date: 28.4.2013
 Track: TCM 2013