

S10 TC BLAST 2

SETUP SHEET

FRONT SUSPENSION

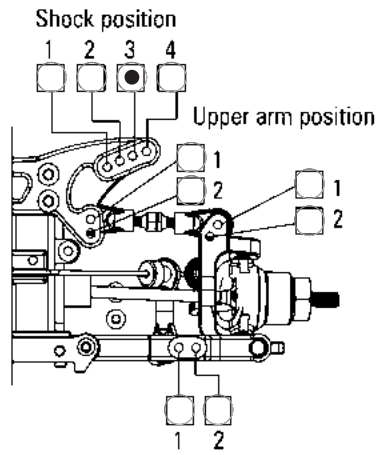

Caster angle
 Standard: 10°
 Option: 4°

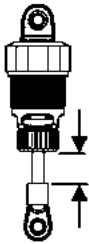
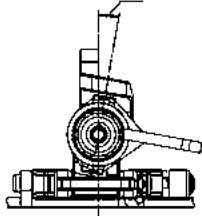

Front shock
 Oil: LRP 50
 Pistons: std
 Spacer: 0 mm
 Springs: Weiß

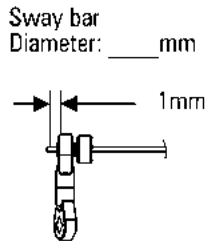

Toe angle

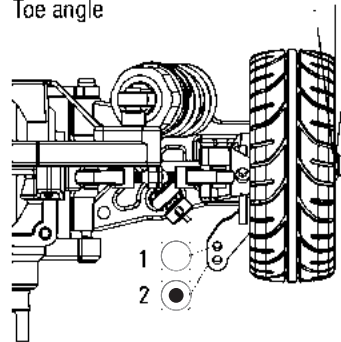

Front toe angle 0°
 Notes
 Rear toe angle 2,5°
 Notes

Camber angle

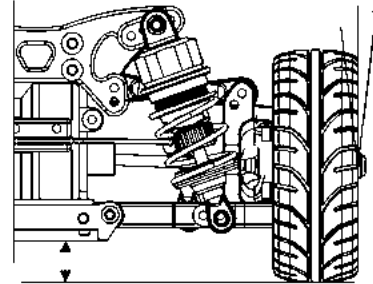

Camber front -1°
 Notes
 Camber rear -1,5°
 Notes

Rideheight front 5,5mm
 Rideheight rear 5,5mm

REAR SUSPENSION

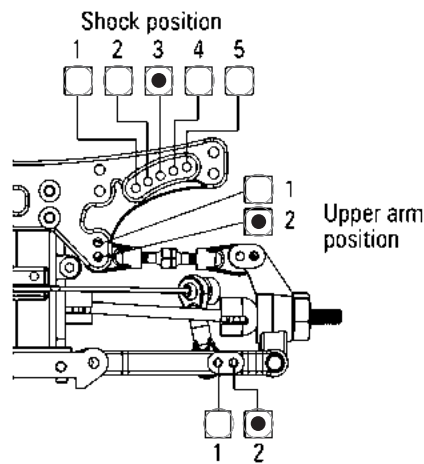

Wheelbase adjustment

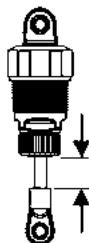
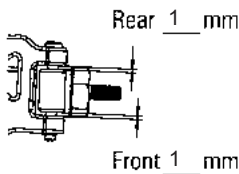

Rear shock
 Oil: LRP 50
 Pistons: std
 Spacer: 0 mm
 Springs: weiß

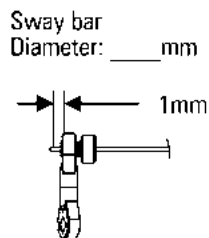

Tire

Front Rear
 Type: Classic Wheel Type: Classic Wheel
 Foam: Foam:

Motor: LRP X12 17,5 Battery: LRP 4600 Lipo
 Spur Gear: 58 ESC: SXX Stock Spec
 Pinion Gear: 28 Servo: Sanwa SDX 801

Track conditions

Size: Open Med Tight
 Traction: High Med Low
 Surface: Carpet Asphalt

Diff Oil

Front: LRP 15000wt
 Rear: LRP 15000wt

Comment

Chevrolet Camaro Z28R 1969 Karosserie 200mm

Name: Florian Schimm
 Date: 28.04.2013
 Track: TCM Althengstett