

SIOBLAST BX

SETUP GUIDE

FRONT SUSPENSION

Shock position

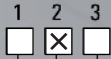

Caster angle
Standard: 10°
Option: 4°



Upper arm position

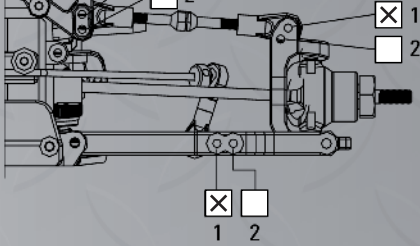

Front shock
Oil: LRP 40 WT
Pistons: org.
Spacer: 3mm
Springs: white

Sway bar
Diameter: 1,6 mm

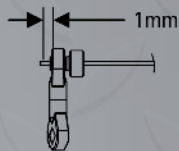

Toe angle

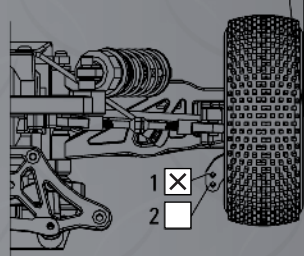

Front toe angle -1,5°

Notes _____

Rear toe angle 2,5°

Notes _____

Camber angle

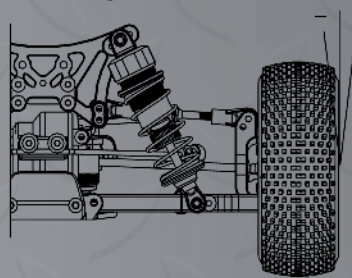

Camber front -0,5°

Notes _____

Camber rear -1,0°

Notes _____

Rideheight front arm level

Rideheight rear arm level

REAR SUSPENSION

Shock position

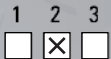

Wheelbase adjustment

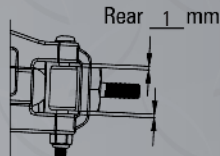

Upper arm position

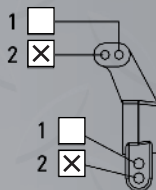
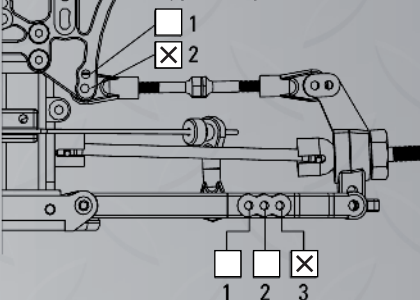
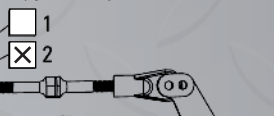

Rear shock
Oil: LRP 50WT
Pistons: org.
Spacer: 4,5m
Springs: white

Sway bar
Diameter: 1,5 mm

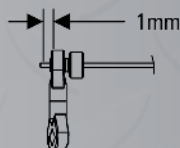

Tire

Front

Rear

Type: 65552J

Type: 65550J

Foam: org.

Foam: org.

Motor: LRP X12 10,5T

Battery: LRP 6900 50C

Spur Gear: 72T

ESC: LRP Flow Comp.

Pinion Gear: 21T

Servo: Sanwa SDX-801

Track conditions

Size: Open Med Tight

Traction: High Med Low

Surface: Smooth Med Bumpy

Diff Oil

Front: LRP HiTemp 5.000WT

Rear: LRP HiTemp 10.000WT

Comment

Name: Mirco Thalheimer

Date: 16.12.2012

Track: LOC Neu-Ulm