

# SIOBLAST BX

## SETUP GUIDE

### FRONT SUSPENSION

Shock position

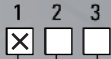

Caster angle  
Standard: 10°  
Option: 4°



Upper arm position

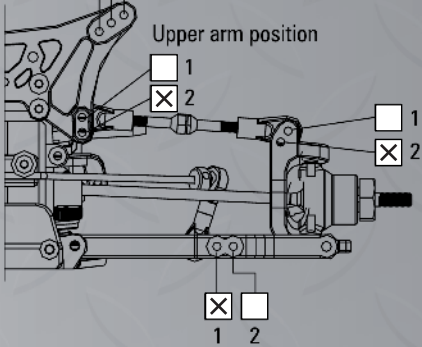

Front shock  
Oil: 40  
Pistons: 4  
Spacer: 2mm  
Springs: black

Sway bar  
Diameter: 2 mm

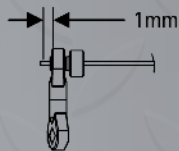

Toe angle

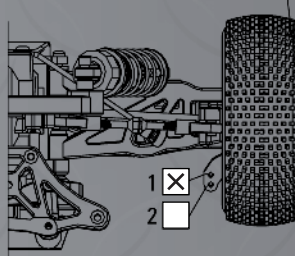

Front toe angle 1-  
Notes \_\_\_\_\_  
Rear toe angle 3+  
Notes \_\_\_\_\_

Camber angle

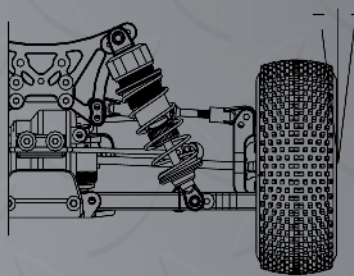

Camber front 1,5-  
Notes \_\_\_\_\_  
Camber rear 1,5-  
Notes \_\_\_\_\_

Rideheight front 9,5mm  
Rideheight rear 10mm

### REAR SUSPENSION

Shock position

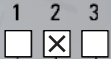

Wheelbase adjustment



Upper arm position

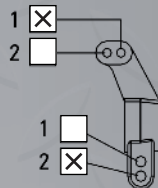
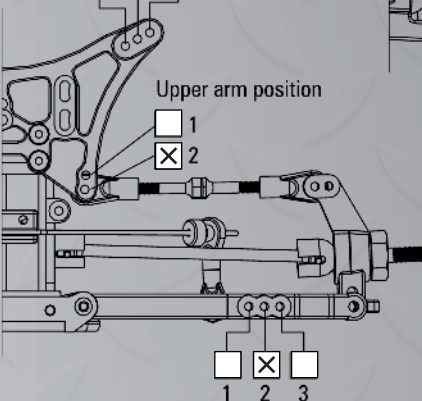

Rear shock  
Oil: 35  
Pistons: 4  
Spacer: 0mm  
Springs: black

Sway bar  
Diameter: 2 mm

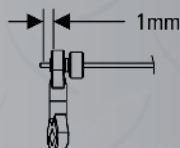

Tire

Front Type: LRP Kamikaze Rear Type: LRP Kamikaze  
Foam: stock Foam: stock

Motor: LRP X12 10,5t Battery: LRP 6900  
Spur Gear: 72 ESC: LRP SXX Stockspec  
Pinion Gear: 26 Servo: Sanwa SDX 801

Track conditions

Size:  Open  Med  Tight  
Traction:  High  Med  Low  
Surface:  Smooth  Med  Bumpy

Diff Oil

Front: Fett  
Rear: Fett

Comment

DM Setup LRP Offroad Challenge 2012

Name: Meik Niemann

Date: 14.09.2012

Track: MAC Burgdorf